

SENSOR FEATURES:

- High sensitivity to a wide range of flammable gases.
- Non-specific response, calibration factors available upon request.
- Typical response time <1 minute to 90% full scale.
- Environmental temperature range of -20 to 50°C.
- Minimal response to environmental humidity over the range of 0 – 95%, non-condensing
- Rugged, reliable sensor based on Synkera’s exclusive technology.

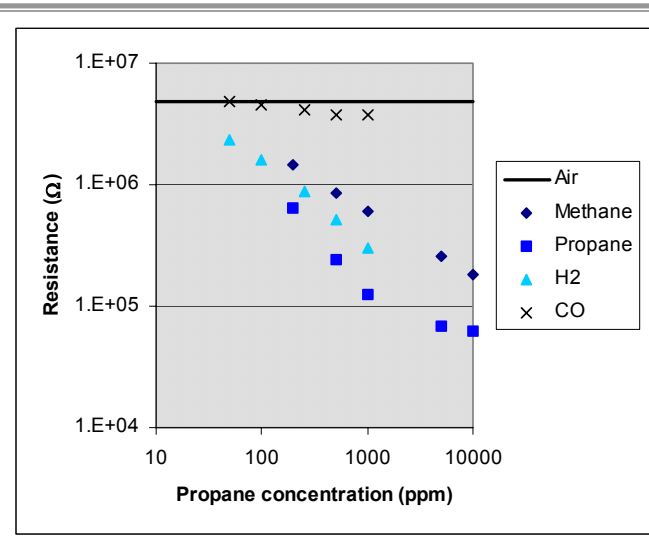

Sensor Resistance as a function of concentration for several flammable gases

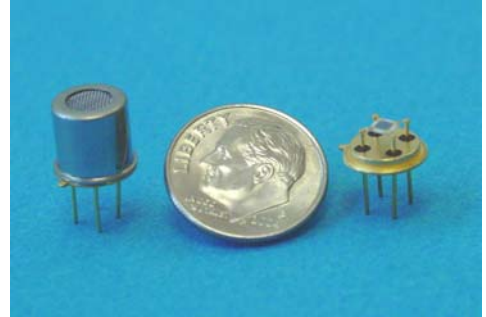
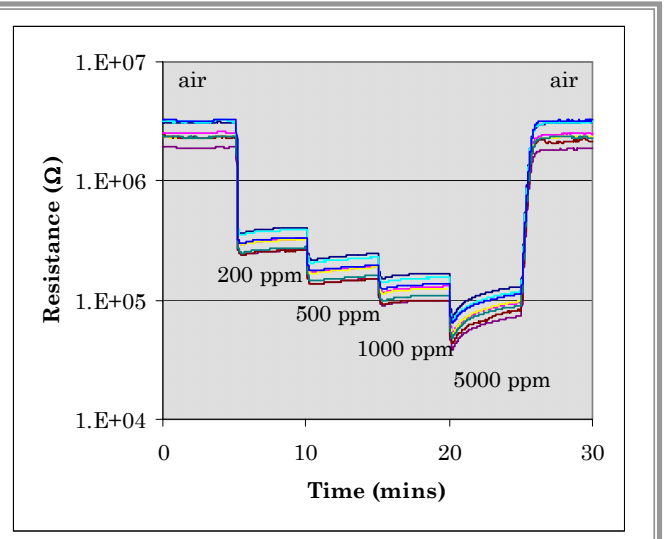

Typical sensor response to propane in a humid environment

Electrical Characteristics

The electrical properties below are typical for Flammable Gas Sensors. If the actual values differ the customer will be notified with the shipment. Circuits are available that will be preset to the correct values.

Property	Symbol	Value	Remarks
Heater Power Consumption	P_H	~ 900 mW	At $V_H = 5.3V$
Heater Voltage	V_H	5.3 VDC	$T_{sensor} \sim 300^\circ C$
Heater Resistance	R_H	$32 \Omega \pm 2 \Omega$	At room temperature
Sensing Voltage	V_C	5.0 VDC	Recommended

Circuitry

A transducer is available from Synkera to operate the sensor. This circuit, packaged on a 2" x 1.5" printed circuit board, is powered with 9 – 24 VDC. The transducer provides a 0 – 5 VDC output which can be adjusted for sensor offset and gain. The heater voltage is also adjustable. The circuit is set to the recommended values at the factory.

Basic Measuring Circuit

The sensor can be operated using a simple voltage divider. This requires two voltage supplies: heater voltage (V_H) and circuit voltage (V_C). V_H is applied to the heater in order to maintain a constant, elevated temperature, for optimum sensing. V_C is applied to allow a measurement of the output voltage (V_{out}) across a load resistor (R_L).

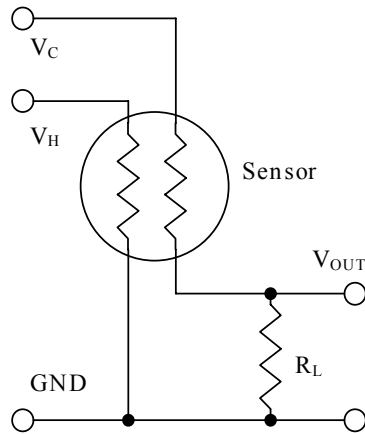

Pins 1 and 3 on the TO-39 header are attached to the heater. Apply V_H across these pins.

Pins 2 and 4 on the TO-39 header are attached to the resistive sensor element. Connect these pins in the measuring circuit.

Sensor Pin Out

Top view of sensor

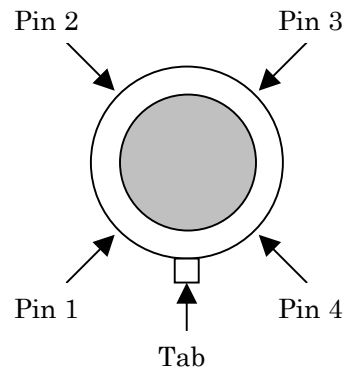

Synkera Technologies strives to be customer oriented. If you have a special application you would like to discuss, or questions you would like answered please contact us at sensors@synkera.com.

Sensor Resistance Calculation

Sensor Resistance (R_s) is calculated using the following formula:

$$R_s = \frac{V_C - V_{out}}{V_{out}} * R_L$$